

1 INDEX

2 MACHINE AND MANUFACTURER IDENTIFICATION
3 FACSIMILE COPY OF EU DECLARATION OF CONFORMITY
4 MACHINE DESCRIPTION
5 GENERAL WARNINGS
6 SAFETY INSTRUCTIONS
7 PERFORMANCE SPECIFICATIONS
8 ELECTRICAL SPECIFICATIONS
9 OPERATING CONDITIONS
10 ENVIRONMENTAL CONDITIONS
11 ELECTRICAL POWER SUPPLY
12 SAFETY INSTRUCTIONS
13 CONNECTIONS
14 INITIAL START-UP
15 DAILY USE
16 MAINTENANCE
17 NOISE LEVEL
18 PROBLEMS AND SOLUTIONS
19 DEMOLITION AND DISPOSAL
20 EXPLODED VIEWS
21 OVERALL DIMENSION

2 MACHINE AND MANUFACTURER IDENTIFICATION

AVAILABLE MODELS: PANTHER DC 12V - PANTHER DC 24/12V
PRODUCT CODE: F0034300C
MODEL: PANTHER DC 12V
TECHNICAL DATA: 3000rpm, 56l/min
MANUFACTURER: Piusi S.p.A., Via Pacinotti 16/A, Z.I. Rangavino, 46029 Suzzara (MN) Italy

3 FACSIMILE COPY OF EU DECLARATION OF CONFORMITY

The undersigned Piusi S.p.A. Via Pacinotti 16/A z.i. Rangavino 46029 Suzzara - Mantova - Italy
HEREBY STATES under its own responsibility that the equipment described below:
Description : Pump for the transfer of diesel fuel
Model: PANTHER DC 12V - PANTHER DC 24/12V
Serial number: refer to Lot Number shown on CE plate affixed to product
Year of manufacture: refer to the year of production shown on the CE plate affixed to the product
complies with the following legislation:
Machinery Regulations
Electromagnetic compatibility
The technical file is at the disposal of the competent authority following motivation requested at Piusi S.p.A. or following request sent to the e-mail address: doc_tec@piusi.com.

4 MACHINE DESCRIPTION

Table with 2 columns: Component and Description. Includes PUMP, MOTOR, and FILTER.

4.1 MOVING AND TRANSPORT

FOREWORD Due to the limited weight and dimensions of the pumps, special lifting equipment is not required to handle them.
STORAGE - Store in a covered and dry place.
- Store the unit away from dirt and vibration

5 GENERAL WARNINGS

Warnings To ensure operator safety and to protect the dispensing system from potential damage, workers must be fully acquainted with this instruction manual before attempting to operate the dispensing system.
Symbols used in the manual

Table with 3 columns: MODEL, WEIGHT (Kg), PACKAGING DIMENSION (mm). Rows for PANTHER DC 12V and PANTHER DC 24/12V.

6 SAFETY INSTRUCTIONS

Mains - preliminary checks before installation
Maintenance control
FIRE AND EXPLOSION
ELECTRIC SHOCK
Electrocution or death
EQUIPMENT MISUSE
TOXIC FLUID OR FUMES HAZARD
HOT SURFACES

7 FIRST AID RULES

PERSONS WHO HAVE SUFFERED ELECTRICAL SHOCK
PERSONAL PROTECTIVE EQUIPMENT THAT MUST BE WORN
OTHER DEVICES
PROTECTIVE GLOVES

8 GENERAL SAFETY RULES

Essential protective equipments
SAFETY SHOES
Close-fitting clothing
Protective gloves
SAFETY GOGGLES
Instruction manual
Prolonged contact with the treated product may cause skin irritation; always wear protective gloves during dispensing.

9 TECHNICAL DATA

Table with 5 columns: Voltage (V), Absorption (A), Power (W), RPM, Nominal Flow Rate (l/min). Rows for PANTHER DC 12V and PANTHER DC 24/12V.

ATTENTION The curve refers to the following operating conditions: Fluid: Diesel Fuel, Temperature: 20°C
NOTE The pumps have been designed for intermittent use and a 30-minute duty cycle under conditions of maximum back pressure.
FUNCTIONING under by-pass conditions is only allowed for short periods of time (max. 3 minutes).

10 ELECTRICAL SPECIFICATIONS

Table with 4 columns: PUMP MODEL, FUSES, ELECTRICAL POWER CURRENT, CURRENT Maximum(A). Rows for PANTHER DC 12V and PANTHER DC 24/12V.

11 OPERATING CONDITIONS

TEMPERATURE: min. -20 °C / max. +60 °C
RELATIVE HUMIDITY: max. 90%
ATTENTION The temperature limits shown apply to the pump components and must be respected to avoid possible damage or malfunction.
11.2 ELECTRICAL POWER SUPPLY
NOTE THE PUMP SHOULD BE POWERED BY A SAFE SOURCE: BATTERY OR POWER SUPPLY 12V/24V WITH SAFETY TRANSFORMER.

11.3 DUTY CYCLE

NOTE The pumps have been designed for intermittent use and a 30-minute duty cycle under conditions of maximum back pressure.

11.4 FLUIDS PERMITTED / FLUIDS NOT PERMITTED

Table with 2 columns: Fluids Permitted and Fluids Not Permitted.

12 INSTALLATION

12.1 PRELIMINARY INSPECTION
Verify that all components are present. Request any missing parts from the manufacturer.
Check that the machine has not suffered any damage during transport or storage.
Carefully clean the suction and delivery inlets and outlets, removing any dust or other packaging material that may be present.

12.2 POSITIONING THE PUMP

The pumps can be installed in any position (with pump axis in vertical or horizontal position).
ATTENTION It is the responsibility of the installer to provide the necessary accessories to ensure the correct and safe operation of the pumps. The accessories that are not suitable to be used with the previously indicated material could damage the pump and/or cause injury to persons, as well as causing pollution.

12.3 NOTES ON SUCTION AND DELIVERY LINES

DELIVERY The selection of the pump model must be made taking into account the characteristics of the system.
SUCTION The self-priming pumps have a good suction capability. During the start-up phase, when the suction pipe is empty and the pump is wet with the fluid, the electric pump unit is able to suck liquid from a maximum vertical distance of 2 m.

ATTENTION It is always advisable to prime the pump without an automatic delivery nozzle, verifying the proper wetting of the pump.
ATTENTION It is very important to keep the suction filters clean because, when they become clogged, they increase the resistance of the system.

ATTENTION If the suction tank is higher than the pump, an anti-siphon valve should be installed to prevent accidental product leak.
ATTENTION IT IS THE INSTALLER'S RESPONSIBILITY TO APPLY THE FOLLOWING SIGNALS ON THE MACHINE ANYWHERE PUMP WILL BE USED.

12.4 LINE ACCESSORIES

ATTENTION It is the responsibility of the installer to provide the necessary line accessories to ensure the correct and safe operation of the pump.
DELIVERY The pumps are furnished without line accessories. Following is a list of the most common line accessories whose use is compatible with the proper functioning of the pumps.

SUCTION ATTENTION The electrical box of PANTHER DC comes with a terminal board for the power cord connection (optional). In case of connection of the cable kit with pliers (Piusi optional), proceed as follows:

13 CONNECTIONS

13.1 ELECTRICAL CONNECTIONS
GENERAL WARNING Comply with the following (not exhaustive) instructions to ensure a proper electrical connection:
1 Before installation and maintenance make sure that power supply to the electric lines has been turned off.
2 Use cables with minimum cross-sections, rated voltages and installation type that are suitable for the characteristics indicated in paragraph "ELECTRICAL SPECIFICATIONS".

- 1 Loosen the cable ring nut with rubber (4) and insert the cable.
2 Open the cable u-bolt (3) which is located inside the electrical box.
3 Fix the eyelet (for screw m4) of the positive cable (blue) to the terminal, in position 1 (see reference in the diagram).
4 Fix the eyelet (for screw m4) of the negative cable (brown) to the terminal, in position 2 (see reference in the diagram).
5 Tighten the u-bolt (3).
6 Screw the ring nut (4).

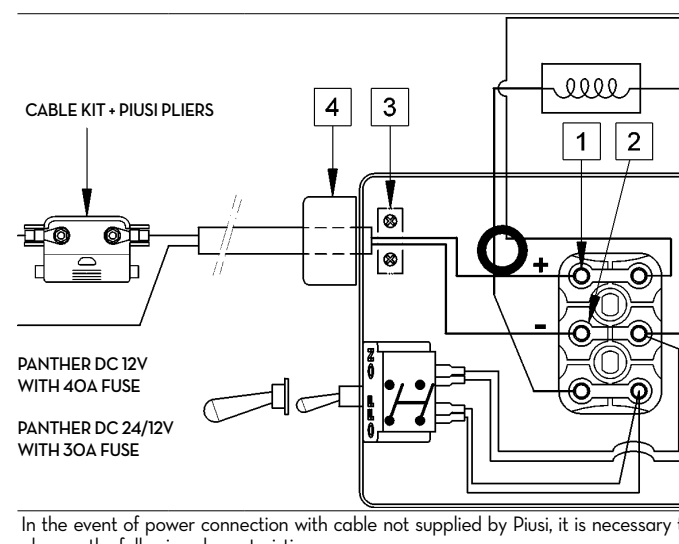

ATTENTION In the event of power connection with cable not supplied by Piusi, it is necessary to observe the following characteristics:
1 for PANTHER DC 12 V - use a bipolar cable with minimum section of 6 mm2
2 for PANTHER DC 24/12 V - use a bipolar cable with minimum section of 4 mm2

13.2 CONNECTING THE PIPING

FOREWORD Before any connections, please refer to the indications (sticker on the pump) to detect suction and delivery univocally.
1 Before connecting, make sure that the pipes and the suction tank are free of dirt and thread residue, which could damage the pump and accessories.
2 Before connecting, make sure that the pipes and the suction tank are free of dirt and thread residue, which could damage the pump and accessories.

ATTENTION THE PROVIDED TUBES HAVE A RESISTIVITY OF ~1 Ohm, as specified by the EN 13617 standard. All the installed tubes that are different from those supplied, must have the above mentioned characteristics.
ATTENTION THE USE OF TUBES THAT ARE NOT SUITABLE COULD CAUSE DAMAGE TO THE PUMP OR TO PERSONS, AS WELL AS POLLUTION.

14 INITIAL START-UP

GETTING STARTED
1 Check that the quantity of diesel fuel in the suction tank is greater than the amount you wish to transfer.
2 Make sure that the residual capacity of the delivery tank is greater than the quantity you wish to transfer.
3 Do not run the pump dry. This can cause serious damage to its components.
4 Make sure that the tubing and line accessories are in good condition. Diesel fuel leaks can damage objects and injure persons.
5 Never start or stop the pump, engaging and disengaging the power.

PRIMING The priming phase can last from several seconds to a few minutes, as a function of the characteristics of the system. If this phase is prolonged, stop the pump and verify:
That the pump is not running completely dry;
That the suction tubing is not allowing air to seep in;
That the suction filter is not clogged;
That the suction height does not exceed 2 m. (if the height exceeds 2 m, fill the suction hose with fluid);
That the delivery tube is allowing the evacuation of the air;

15 DAILY USE

FOREWORD This pump is for professional use only.
USE PROCEDURE 1 If using flexible tubing, attach the ends of the tubing to the tanks. In the absence of an appropriate slot, solidly grasp the delivery tubes before beginning dispensing.
2 Before starting the pump make sure that the delivery valve is closed (dispensing nozzle or line valve).
3 Turn the ON/OFF switch on. The by-pass valve allows functioning with delivery closed only for brief periods.
4 Open the delivery valve, solidly grasping the end of the tubing.
5 While dispensing, do not inhale the pumped product.
6 Close the delivery valve to stop dispensing.
7 When dispensing is finished, turn off the pump.

16 MAINTENANCE

NOTE Maintenance must be performed only by authorized and properly trained personnel.
SAFETY WARNINGS Thanks to the design, the pump requires simple maintenance. Before carrying out any maintenance work, disconnect the pump from any electrical and hydraulic power source.
ONCE A WEEK: Check that the pipe connections are not loose to prevent any leaks.
ONCE A MONTH: Check the pump body and keep it clean and free of any impurities. Check that the electrical supply cables are in good condition.
ATTENTION Do not put your fingers into the pump openings while the pump is working.

17 NOISE LEVEL

Under normal working conditions the noise emission from all models does not exceed the value of 70 db at a distance of 1 meter from the electric pump.

18 PROBLEMS AND SOLUTIONS

Table with 3 columns: Problem, Possible Cause, Corrective Action. Includes issues like Motor not turning, Motor turns slowly when starting, Increased pump noise, Leakage from the pump body.

19 DEMOLITION AND DISPOSAL

FOREWORD If the system needs to be disposed, the parts which make it up must be delivered to companies that specialize in the recycling and disposal of industrial waste and, in particular:
Disposing Of Packaging Materials: Metal parts, whether paint-finished or in stainless steel, can be consigned to scrap metal collectors.
Disposal Of Electric And Electronic Components: These must be disposed of by companies that specialize in the disposal of electronic components, in accordance with the indications of directive 2012/19/EU (see text of directive below).
Information Regarding The Environment For Clients Residing Within The European Union: European Directive 2012/19/EU requires that all equipment marked with this symbol on the product and/or packaging not be disposed of together with non-differentiated urban waste.

Piusi Panther DC logo and exploded view diagram of the pump assembly.

MADE IN ITALY logo, installation manual information, and Piusi.com website branding.

Piusi Fluid Handling Innovation logo and detailed environmental and disposal instructions.

