

# Advanced Fuel Conditioning Unit Tank Level Gauge & MODBUS Version



Complete with 2 micron & 10 micron filtration for particle and water removal, and a magnetic fuel conditioner and control electronics.

# WARNINGS



- Unit is not designed for pumping any fluid other than EN standard diesel fuel or HVO/GTL fuel.
- Do not site the unit adjacent to a petrol dispenser or in a hazardous zone.
- The installation of the unit including the electrical connections must conform to all relevant electrical and local authority regulations and standards.
- The unit should be installed in a well ventilated area, and all cabinets should be ventilated, and the tank designed to accept a fuel conditioning system. Max 2.8m tall tank.
- If the unit is fitted to an above ground tank, please make sure that there is a check valve fitted with the correct spring ratio and pressure relief to suit the tank height. Max suction pressure = -0.3bar, Max delivery pressure = +2.1bar. If in doubt install pressure gauges as per the pump installation manual.
- Unit installation must be performed by a competent fuel installation engineer.
- Make sure there are no warning messages on the front panel or fuel leaks after commissioning.
- Ensure that all relevant staff are trained on the operation of the unit, as part of your fuel installation risk assessment.
- The unit has been pressure tested and function tested after assembly and we recommend the use of union fittings to ensure that the sealed joints are not damaged by installation pipework.
- Fluctuating electrical parameters and fuel additives will reduce the life of the pump. Do not configure the system for cycles greater than 30mins.

# SPECIFICATION

- Fuel Conditioning unit to improve stored fuel quality for up to 40,000 litre tanks
- Multi-pass ISO cleanliness target of 14/13/11 and <60ppm water (lab tested)
- High quality **PIUSI** pumping and metering products.
- Cim-Tek  Ultimate Defense® 10micron and 2micron Hydroglass® media spin on canisters.
- For the conditioning of 1.5x storage tank capacity over 21 days — running between 9am and 5pm, Monday to Friday (un-degraded filters)
- IP55 protected electronics & pump, installed on a rear back plate for easy mounting to a tank.
- Magnetic fuel conditioner for breaking down bacteria molecules and double stage water and particle filtration.
- Custom micro controller with touchscreen indicating operational messages.
- Customisable tank size, run time and degraded set points.
- Pulse meter controlled filter degradation and trending visualisation.
- The internal timer that controls the pre-set time periods that the fuel is circulated, is determined by a pre-set tank volume.
- Mushroom style stop button on the plate to allow the immediate stop of pump functions by anyone.
- In the event of the filters blocking, the screen will display the corresponding message and the pump will switch off until the filter is replaced.
- Leak sensor input—for connecting to the drip tray fitted below the pumping unit.
- Low Fuel Level input for connection to a relay output on a tank gauge or tank alarm system.

- LAN ETHERNET IP MODBUS Gateway (if purchased)
- Integrated Tank Gauge with 4-20mah submersible probe for 3m tall tanks (if purchased)
- Non Latching Input for Low Level / Leak (N/O); for connecting a tank alarm or electronic gauge to detect a low fuel level. Activates the warning on the control panel and turns off the pump, Leak sensor is included and must be installed in a drip tray below the unit.
- Two passive BMS outputs for remote warning of filter block and low level/leak to alert the user that they need to take action. Low Level and Leak are a shared output.

#### Models Available :

CTS1080 - Advanced Fuel Conditioner Unit

CTS1081 – Advanced Fuel Conditioner Unit – MODBUS

CTS1082 – Advanced Fuel Conditioner Unit – GAUGE

CTS1083 – Advance Fuel Conditioner Unit – MODBUS & GAUGE

All models—For circulating (50lpm) max 3000 litres per day (40,000l tank)

# INSTALLATION

- Ensure all pipework that is to be connected is free of any weld debris / excessive sealant, minimum dimensions of 1" pipework with a max tank height of 2.8m. Suction pipe to be as short as possible and delivery pipe to return to opposite side of tank to gain a cyclic effect. **Non Return Valve** must be installed on suction line including wire strainer.

Max suction pressure = -0.3bar, Max delivery pressure = +2.1bar. If in doubt install pressure gauges as per the pump installation manual.

- Mount the rear plate to the tank or wall with sufficient fixings.  
(See fig 1 —Page 25)
- Connections to the inlet and outlet can be via flexible couplings and union fittings. Flexible coupling must be inspected regularly and changed when required.
- We supply a ball valve for the suction inlet and delivery outlet. These are to be fitted by the installer / fabricator at a point deemed appropriate to the installation to allow simple filter changes.
- If fitted outdoors ensure a rain & sun deflector is installed above the unit.
- Remove the bottom panel to reveal the input terminals—refer to manual and circuit board for connections.
- Ensure the connection pipework is not stressed when connected.
- Use all the plate fixings points where available.
- Ensure the unit can be serviced easily once fitted.

Please note: You must use the leak probe. Create a containment system or drip tray under the unit to aid in filter changing and detection of leaks. If the unit leaks then the system will shut off to prevent the tank emptying. If outdoors—ensure rain / sun shield covers and prevents rain in drip tray.

# INPUTS & OUTPUTS

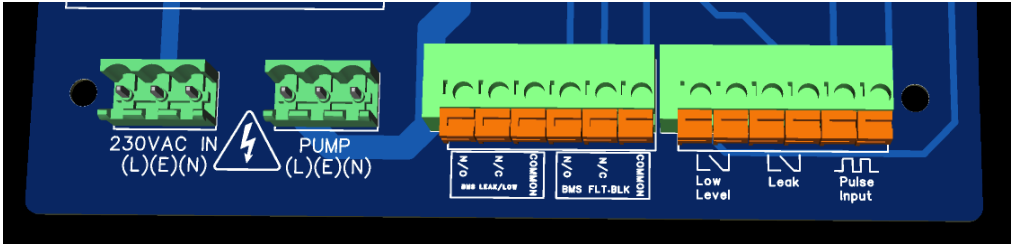

The connections are printed on the circuit board.

Low Level, Leak & Pulse Inputs are not polarity sensitive.

All other connections are polarity sensitive.

We recommend terminating the wires in a ferrule before connecting to the pump or mains terminal block to ensure a positive reliable connection. Check that the polarity is correct once the terminals are installed.

Use a flat blade screwdriver to open the constant tension contacts, pre-twisting the exposed core and push fully to insert. Use 0.2mm<sup>2</sup> to 1.5mm<sup>2</sup> cables

## Level Gauge Connections

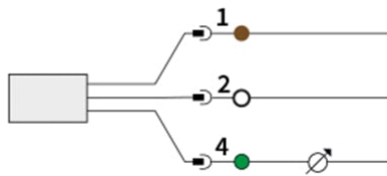
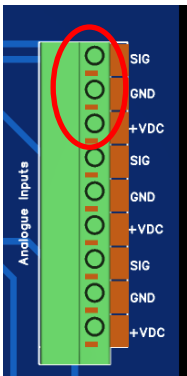

1 = **BROWN** >>>> +VDC

2 = **WHITE** >>>> NOT CONNECTED

4 = **GREEN** >>>> SIGNAL



# MODBUS Connection

192.168.1.5

Fixed IP

\*\* Can be changed by connecting to the host webpage and modifying settings, such as DHCP and IP configurations.

Customer BMS Ethernet Network connection to RJ45 socket inside enclosure



## MODBUS Reference Table

FUNCTION	DECIMAL	HEX
Leak Alarm	6	6
Low Fuel Level	5	5
High Fuel Level	53	35
High—High Fuel Level	54	36
Filters Degraded	7	7
Filter Blocked	8	8
Pulse Rate	12	c
Pump Run (mins)	26	1a
Pump Run (secs)	24	18
Pump Running Flag	39	27
Total Litres Processed	14	e
Tank Level	94	5e

# INITIAL CONFIGURATION

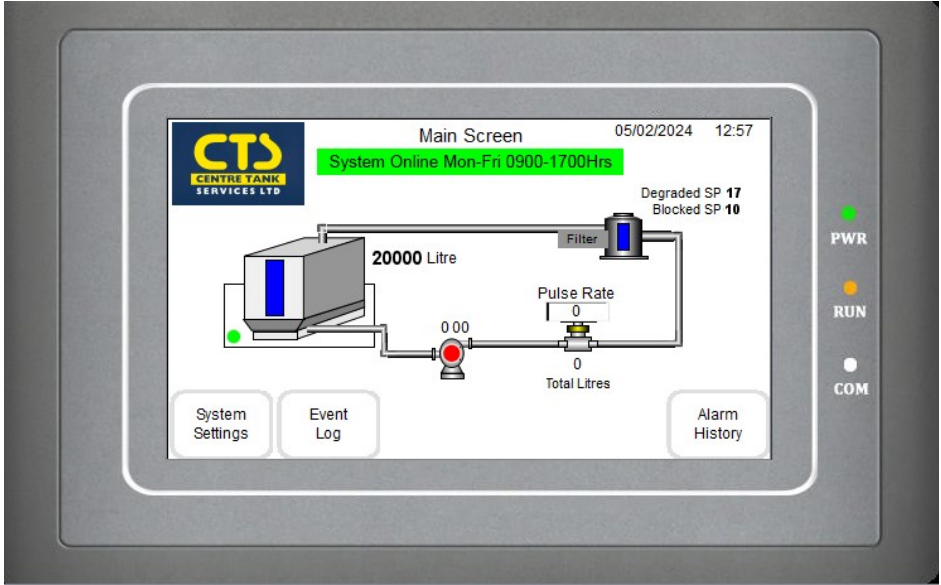

The default screen will display the factory pre-set information.

PRESS "System Settings" Button, then PRESS "Engineer Login Menu"



PRESS "User Login" button

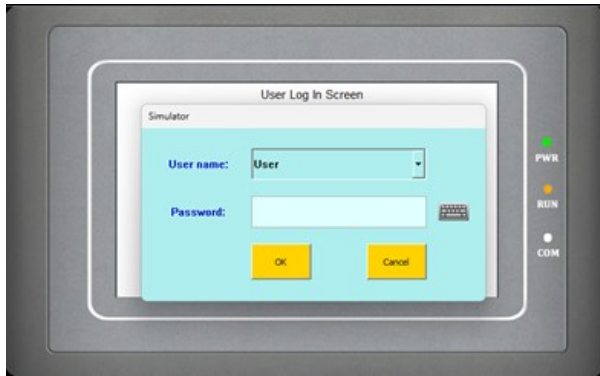

Select the Dropdown Box to say "Engineer"

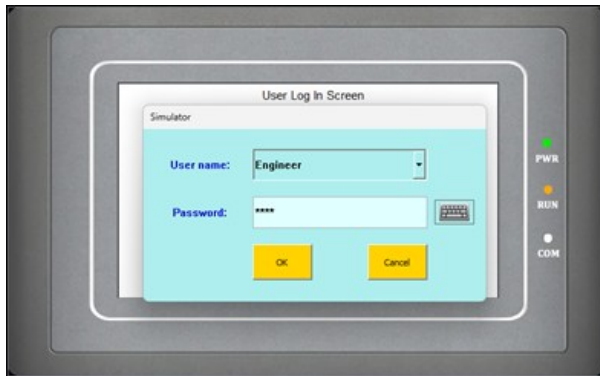

ENTER PIN Number \*\*\*\* (Supplier of Equipment will have this)

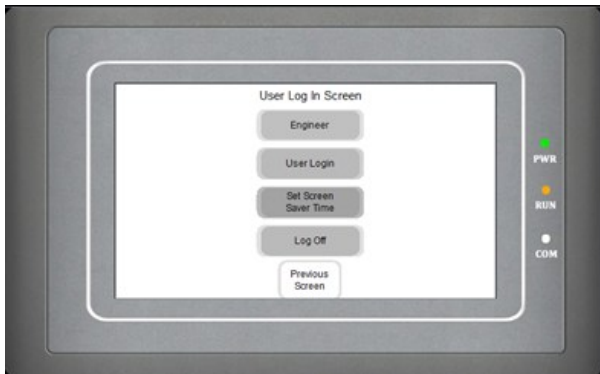

Panel is now in Engineer mode—set the screensaver time here and then PRESS "Previous Screen" button

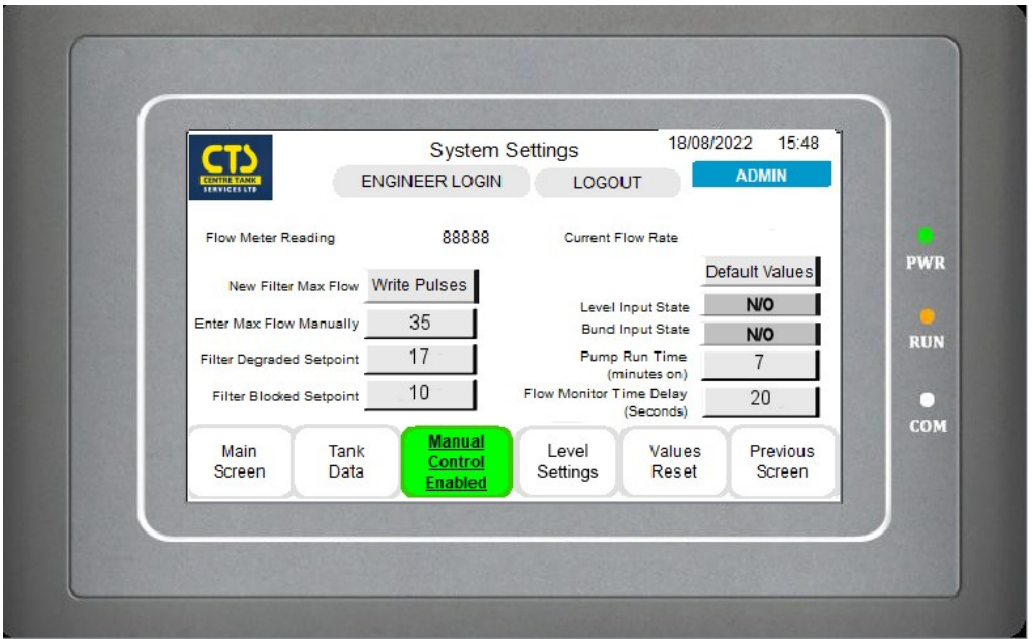

The set-point information has been pre-configured to suit the Panther 56 pump that is installed on the unit and to ensure the pump does not run outside of its working pressure curve.

The pump run time can be configured by the engineer based upon the TANK DATA screen recommendations or adjusted to give a custom run parameter.

The flow delay is configured here to allow for larger installations that could potentially loose prime—acts like a self priming timer to ignore the flow until its stabilised after starting a cycle.

The Input logic is fixed at Normally Open

The Output logic is Normally Open but an engineer could change the connections on the relay board to give Normally Closed output —depending upon the BMS input requirements.

PRESS “Level Settings” Button

To exit manual control mode, hold “manual control” button for 2 secs.

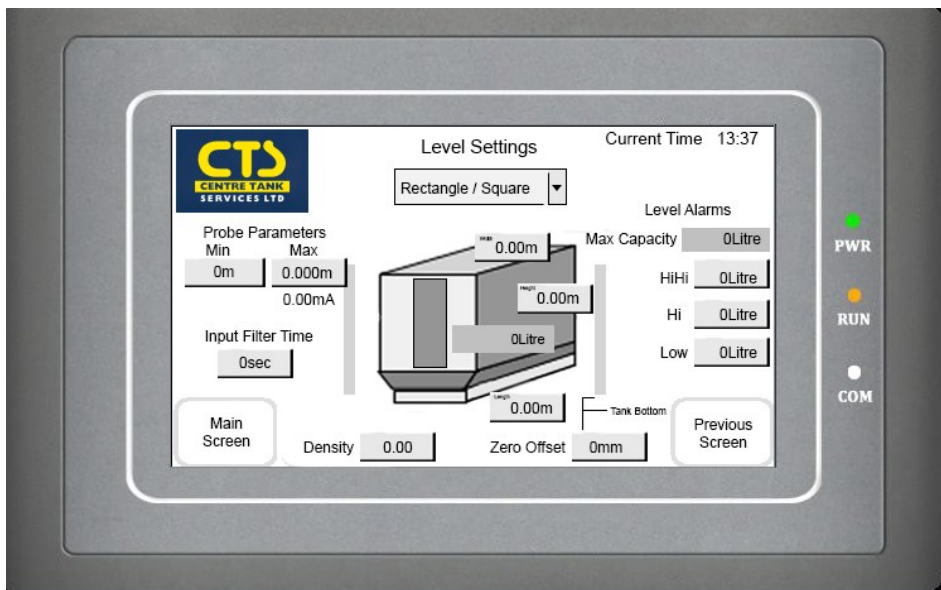

Select the Tank Shape from the dropdown list



PRESS “Max probe box” parameter and enter “3”

PRESS “Input Filter box” parameter and enter “3” (Input filter parameter must be set to 3)

PRESS “Density Input box” parameter and enter the fuel density (e.g. 0.84)

PRESS “Height box” parameter and enter the internal tank height (m)

PRESS “Width box” parameter and enter the internal tank width (m)

PRESS “Length box” parameter and enter the internal tank width (m)



### Reboot the System

Re-Enter this menu to confirm the probe display is working correctly

PRESS “Hi Hi Level box” parameter and enter (suggested) 95% tank capacity (litres)

PRESS “Hi Level box” parameter and enter (suggested) 90% tank capacity (litres)

PRESS “Low Level box” parameter and enter a low fuel level warning (litres)

PRESS “Zero Offset box” if the probe is not touching the base of the tank (mm)

Adjust the tank dimensions to give the correct Max Capacity of the tank—contact the tank manufacturer for accurate dimensions.

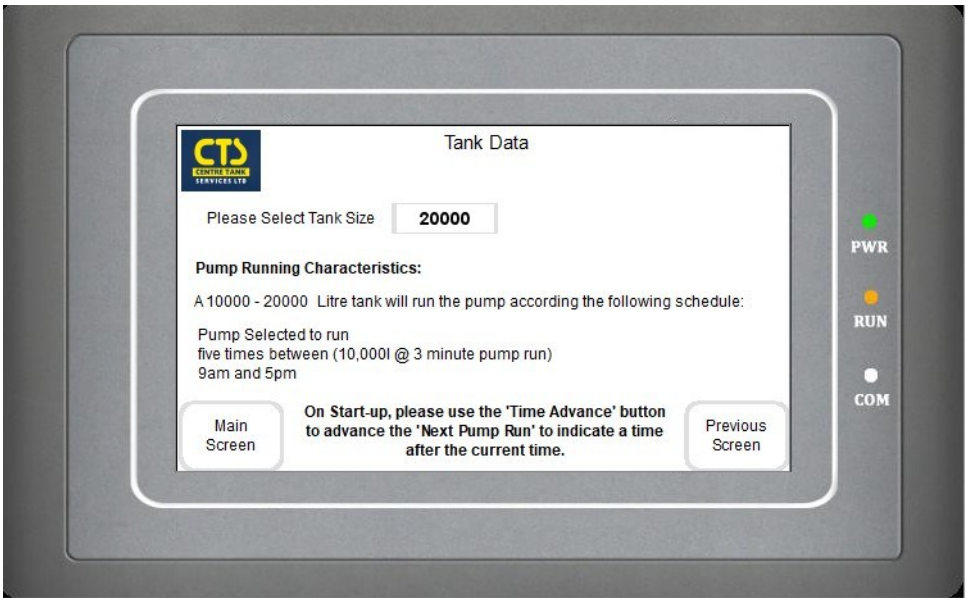

The tank data is pre-set from the live tank level data. However in certain situations the tank data can be overridden to run the pump more often.

PRESS “Schedule Override” button to enable this feature.

PRESS “Tank Size” Field

Enter the tank size required

Information and suggested run times will be given and preconfigured for a range of tank sizes to ensure 1.5 x the tank size is being conditioned every month based on Mon—Fri 9am to 5pm.

*Example :- 20,000l tank size selected = 50 lpm x 7mins run = 350 litres per run*

*350 x 5 runs in one day then multiply by 21 days = 36,750 avg per month*

*Note—If you want to run a SUPER CLEAN on a smaller tank then set the tank size to 40,000l and set the pump run time to 10 mins. You will now condition approx 4,500l per day or 94,500l per month—but be aware you will reach the pump service life quicker,....and require a pump & filter change earlier than expected.*



The system is configured with a Fuel Tanker Filling screen. Pressing this button from the main menu enlarges the litre display of the tank.

This display will update on the frequency of the INPUT FILTER set in the tank information screen.

Any alarms will be visible on a large banner on the screen

## High Level

To confirm any alarms or to go back to the main screen **PRESS** "Home" button

This screen is also the screen saver display allowing any militance operatives to quickly see and visible alarms.

# RUN SCHEDULE INFORMATION

PRESS “View Schedule” Button on Main Screen

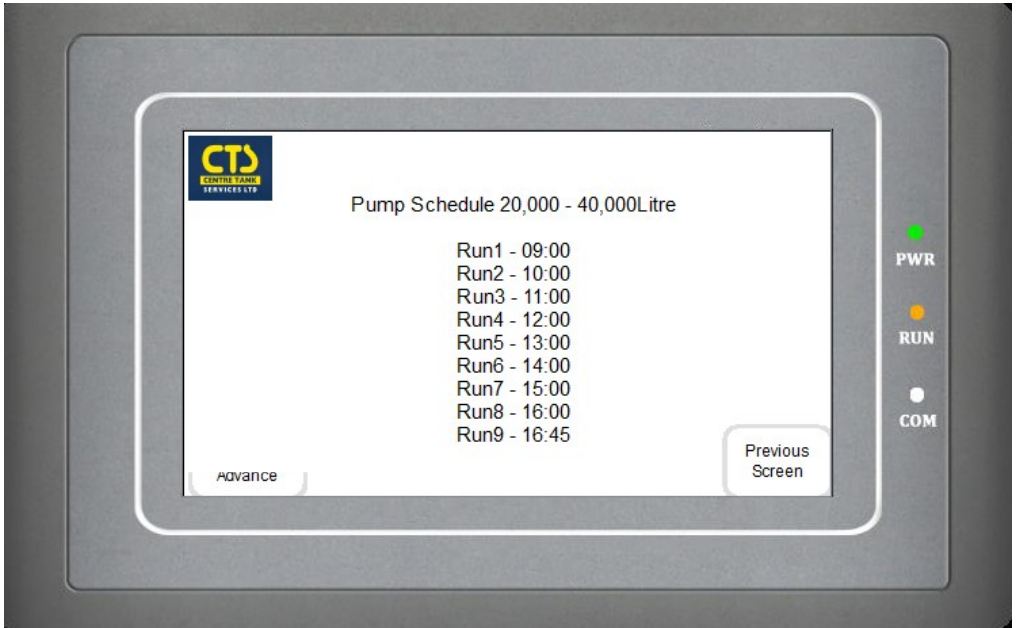

The schedule displayed is based upon the tank data from the level gauge or from the tank data override.

The unit is programmed to run during daytime working hours only.

Mon—Friday 9am to 5pm

# EVENT LOGGING & TRENDING

PRESS “Event Log” Button on Main Screen

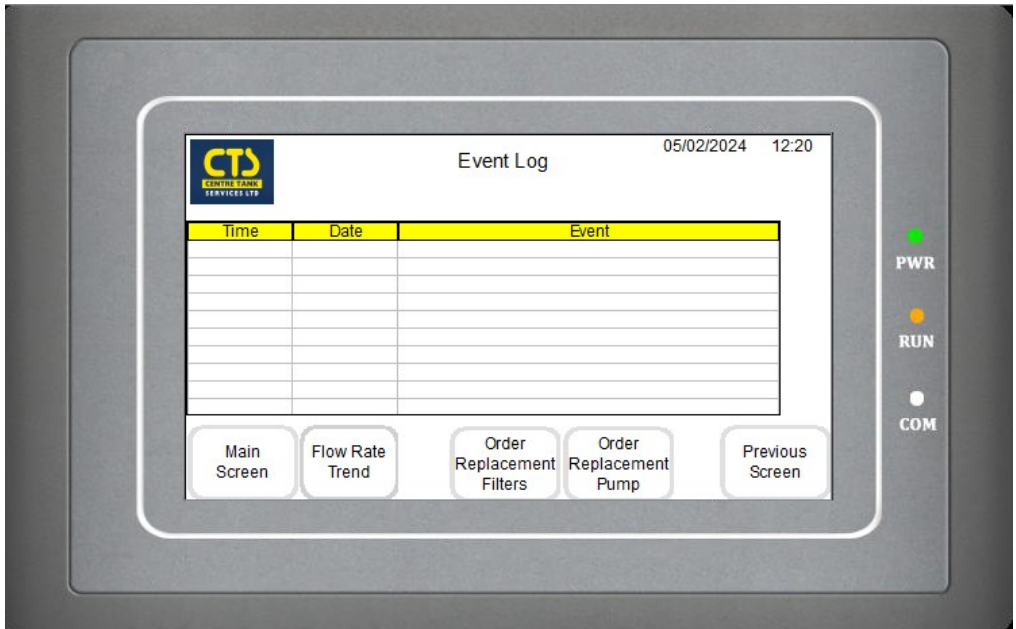

The Event Log displays a history of the working of the fuel conditioner and can be checked by on-site maintenance personnel to ensure correct operation of the unit or to troubleshoot.

The following are time stamped with HH:MM:SS

Pump Started

Pump Stopped

Low Fuel Level

PRESS “Flow Rate Trend” Button on Main Screen

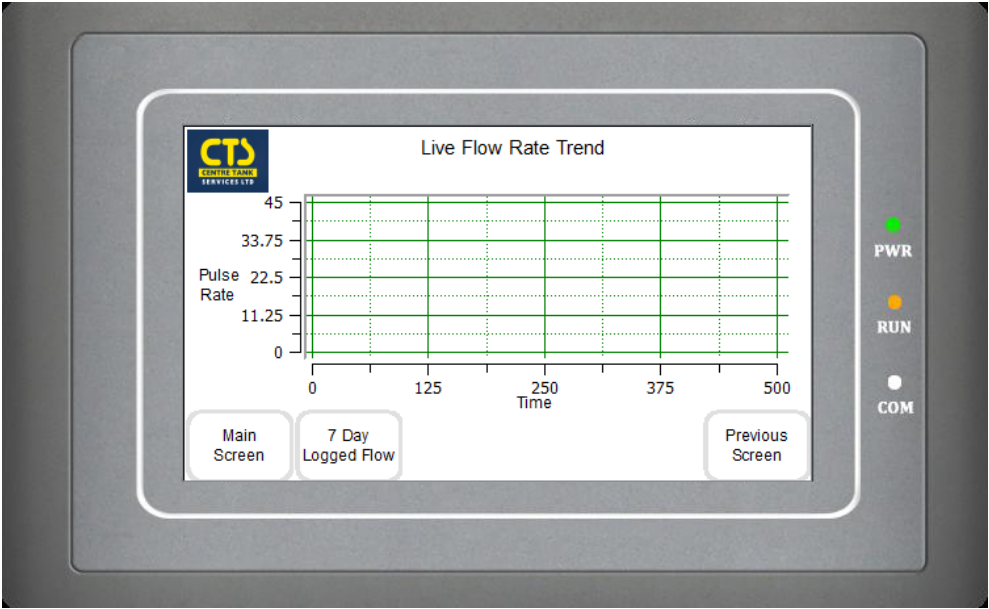

The flow rate trend can be viewed on this screen during pump running only and any reduction in flow can be visibly seen and the filters changed before any warnings are displayed, best viewed late in the day.

PRESS “7 Day Logged Flow”

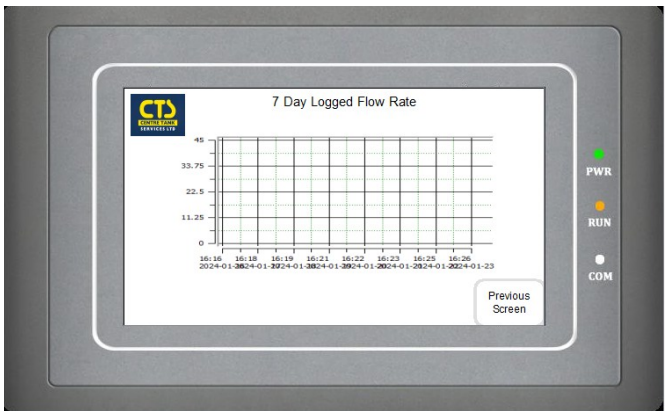

Longer flow trends can be displayed too—useful for historical checking

# LOW FUEL LEVEL ALARM

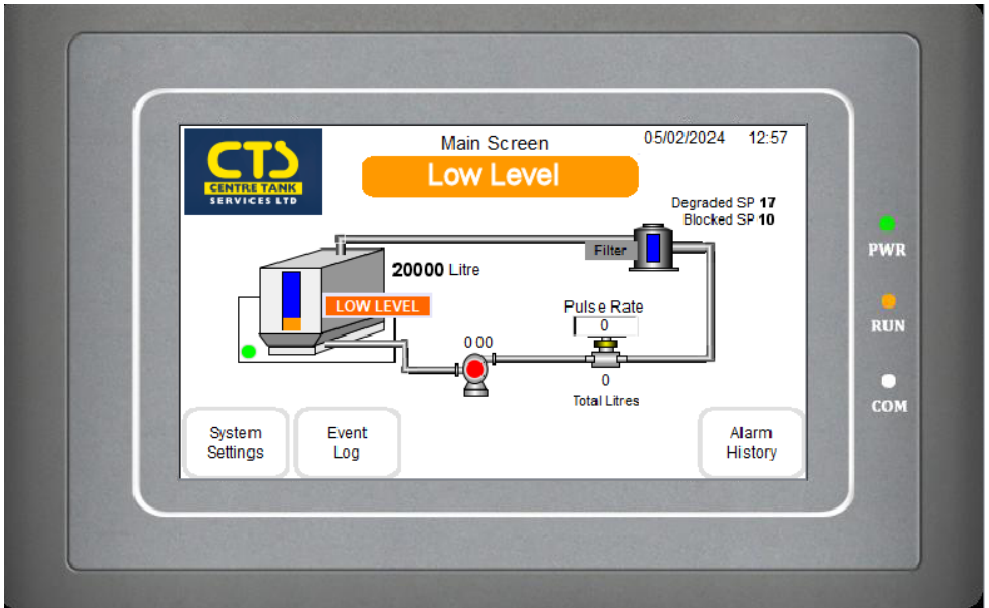

The system is fitted with a Low Fuel Level input terminal. This feature will pause the operation of the pump until the storage tank fuel level returns to normal, therefore automatically recovering from this situation and not reporting a filter block error as there is no fuel passing through the unit.

Connect the relay output on a tank alarm or tank gauge to the corresponding input terminals on the fuel conditioner.

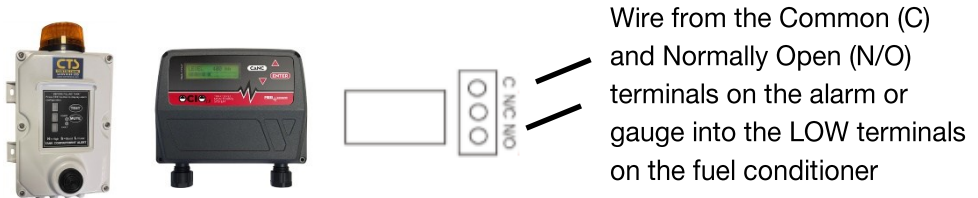

The Low Fuel Level is reported in the alarms screen log

There is 1 x shared volt free contact for connection to a BMS or other external equipment that activates on either/both Low Level or Leak Alarm.

# LEAK ALARM

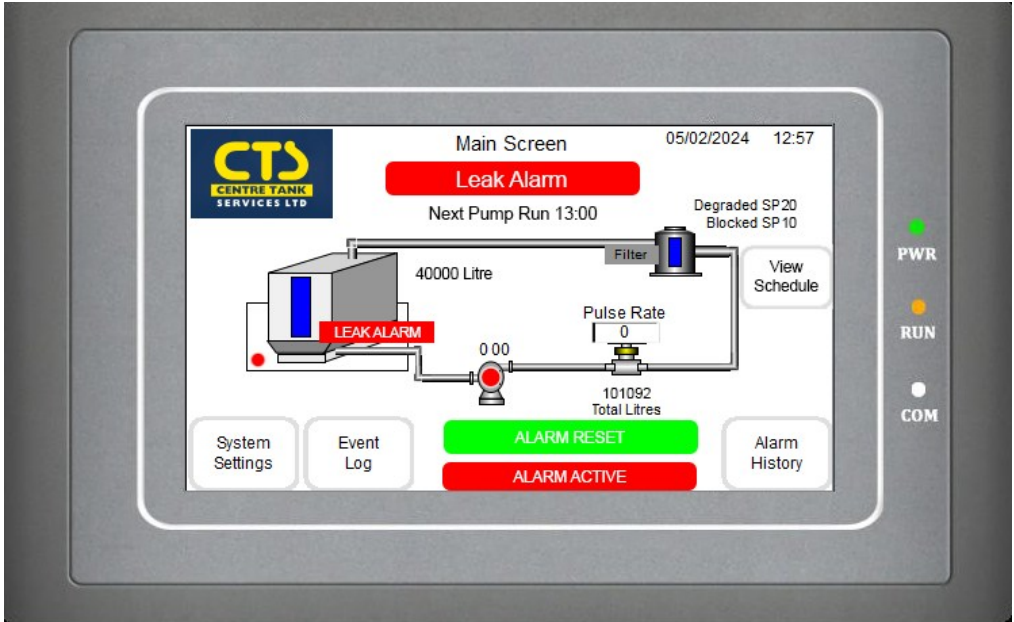

If the leak alarm sensor activates then the unit will stop operation.

This is to prevent emptying of the tank if the unit or attached pipework develops a leak and will prevent the unit from continuing to operate.

Manual user intervention is required to **RESET** the alarm after the leak has been solved, before the unit will resume automatic operation.

**PRESS** “Alarm Reset” button

The Leak Alarm is reported in the alarms screen log

There is 1 x shared volt free contact for connection to a BMS or other external equipment that activates on either/both Low Level or Leak Alarm.

# ALARM LOGGING

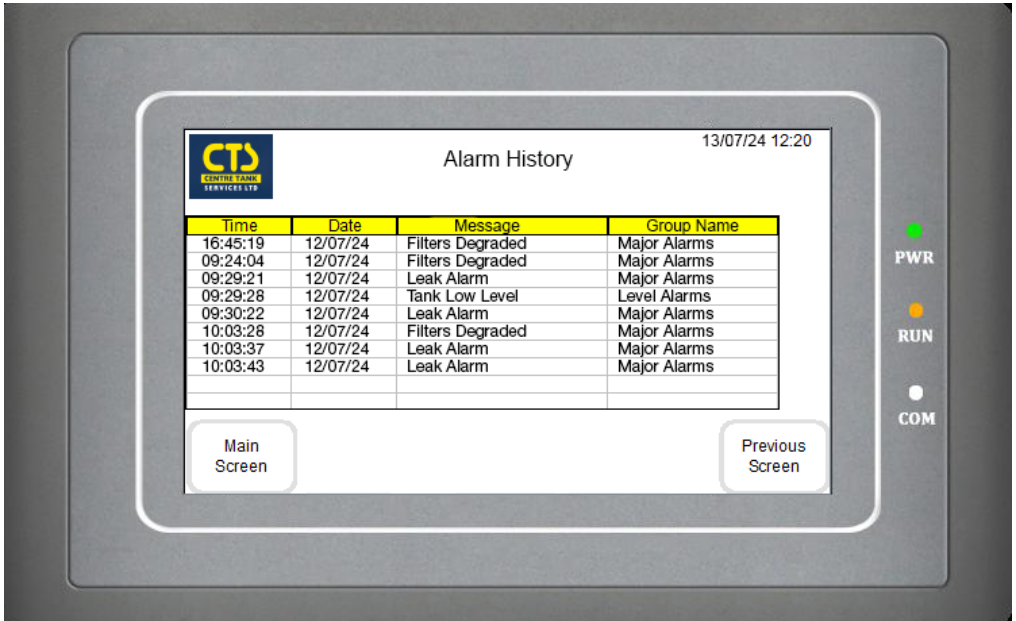

Alarms are registered in the alarm logging section.

This section details important historical alarm information that can be viewed from the home screen by anyone.

Alarms Reported will be in the full time format HH:MM:SS :-

Filters Degraded

Filters Blocked

Leak Alarm

Low Fuel Level

No Max Flow Set

No Flow Delay Set

# DEGRADED FILTERS

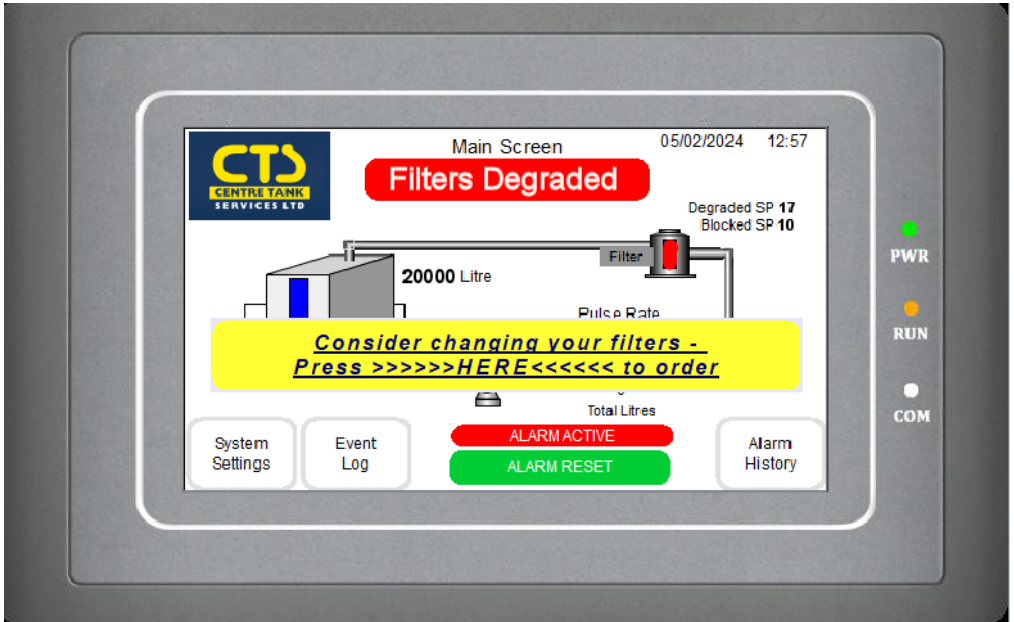

When the filters start to reach the end of their useful life the unit will provide a visual alert on the screen during the current running cycle.

The operator has the option to **RESET** this alarm during the running cycle and see if it re-appears.

The Degraded Filter Alert is logged to the Alarm History Log

This feature allows the customer to re-order new filters by **CLICKING** on the alert box, the unit will continue to run allowing the new filters to be delivered.

## IMPORTANT!

Any servicing engineer will have the degraded filter information in the Alarm History and can choose to change them pre-emptively instead of having to re-visit as the filter life is unknown on other systems.

# BLOCKED FILTERS

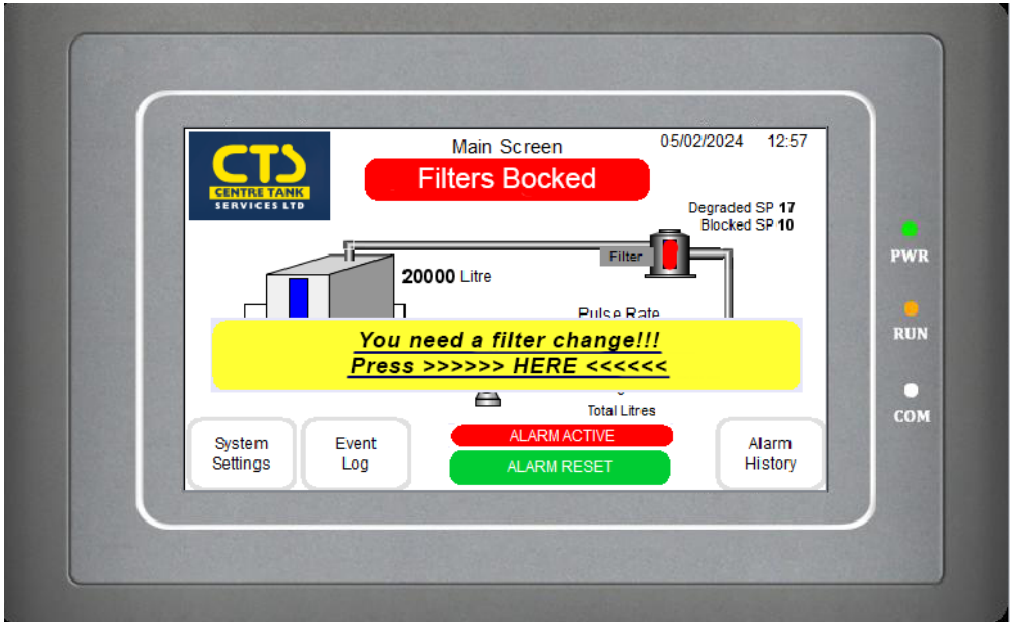

The end user has the option to re-order the new filter canisters from either the QR code or by calling the manufacturer.

CTH1851 - Cim-Tek Hydroglass® Bio Water Filter Element 2 Micron 70037

R14862 - Cim-Tek Hydroglass® Bio Water Filter Element 10 micron 70024

The pump will **STOP** on the Filter Block Alarm and not start again until the filters have been changed and the **ALARM RESET**.

There is 1 x volt free contact for connection to a BMS or other external equipment that activates on the Filter Block Alarm.

# RE-ORDER FILTERS



The end user has the option to re-order the new filter canisters from either the QR code or by calling the advertised contact.

- CTH1851 - Cim-Tek Hydroglass® Bio Water Filter Element 2 Micron 70037
- R14862 - Cim-Tek Hydroglass® Bio Water Filter Element 10 micron 70024

# CHANGING BLOCKED OR DEGRADED FILTER

The unit is fitted with a pulse meter that detects when either of the canister filters are blocked. Upon detection, the PLC will stop the unit, and trigger a passive output to a BMS (if set up). The pump will not reactivate until the blocked filter has been replaced and / or the active alarm reset.

1. **IMPORTANT:** Press the **STOP** button on the plated unit to ensure the pump is isolated from power whilst maintenance is carried out.
2. Turn the lever ball valves off at the fuel inlet and outlet to prevent fuel loss.
3. Unscrew each canister using a filter strap and drain any excess fuel.
4. Inspect the filter head seat and wipe clean
5. Add the new rubber canister seal carefully and lubricate with some oil.
6. Refit each canister and tighten with a strap ensure that the filter gasket remains in the groove on the head.
7. Open the lever ball valve on the fuel inlet and outlet
8. Reset the isolator, Either wait for the next cycle, or enter the engineer menu and put the system in to manual mode to re-prime the canisters.
9. If no flow is detected the pump will switch off again, if this happens repeat step 8 and check valves are in the open position and check valve is not stuck.
10. Dispose of used filters as contaminated waste following onsite guidelines.

# PUMP END OF LIFE

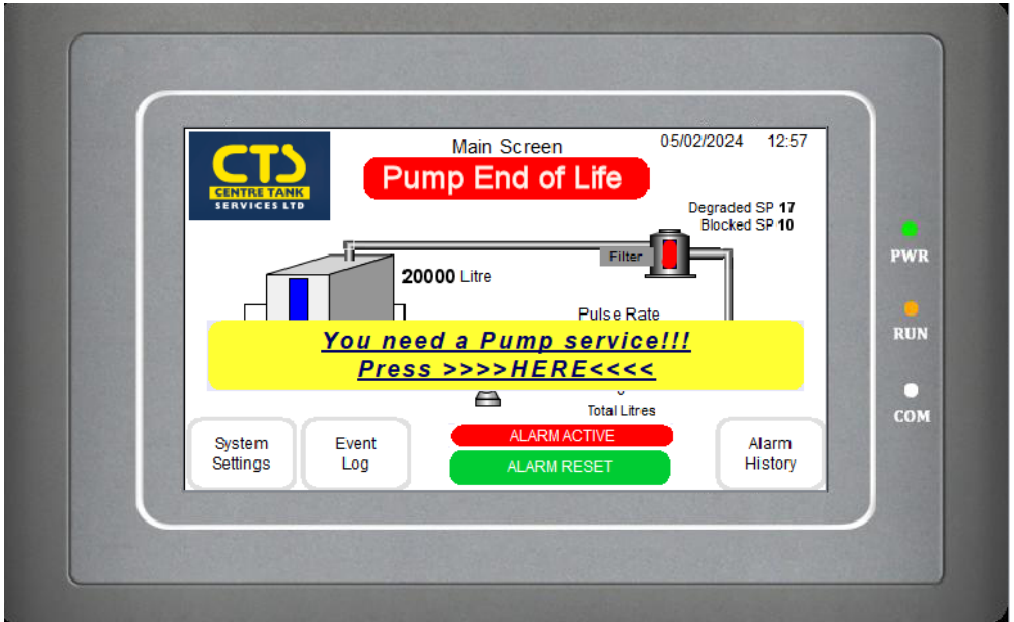

We suggest changing the pump after 1.5million litres processed through the system.

The above message will appear and write the alarm information to the log. Once cleared, the message will re-appear upon a power cycle.



A new pump can be ordered directly from QR code, or from the advertised contact.

# DIMENSIONS

650

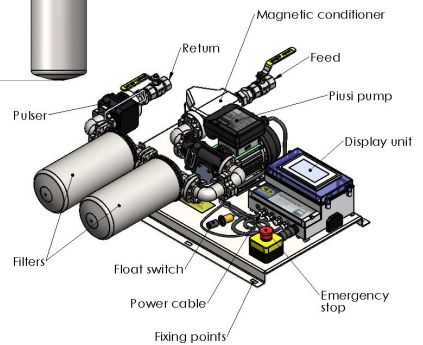
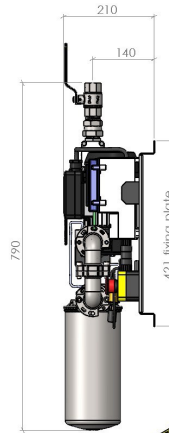
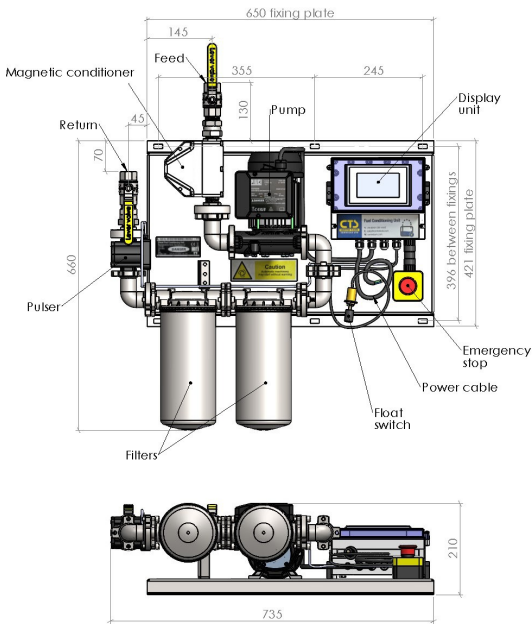
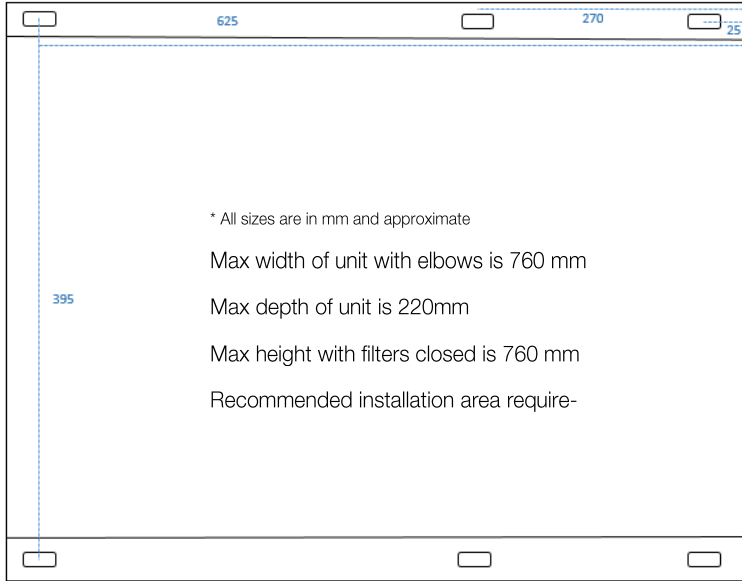

# SERVICING

Please note, when servicing, you must cycle the power to the unit.

Periodic inspection of complete system, and any connection hoses, and changing of the filter media as required. Large /important tanks should have filter media changed regularly. Periodically check the leak sensor and low level inputs are working correctly.

On annual inspection the following should be changed:

- 2 x filter canister media & canister seals
- Vanes and cover o-ring for pump
- Clean pump inlet filter and any other suction strainers
- Confirm pump is operating to declared electrical & hydraulic spec
- Depending upon tank construction it may be necessary to check and clean the magnetic conditioner.
- Consider changing the pump and PSU when unit exceeds 1.5m litres.
- Consider changing the relay pack and PSU after 5 yrs.

# SPARE PARTS

CTH1851—Cim-Tek Hydroglass Bio Water Filter Element 2 Micron 70037

R14862—Cim-Tek Hydroglass Bio Water Filter Element 10 micron 70024

R12066000—Canister Seal x1

R112760000—Vane kit for Panther pump. R11461000—Front o-ring.

**SWS1035**—Float sensor probe for drip tray/leak.

**SWS?????** - AFC Fuse Kit

## OPTIONS

**F0075510D**—230v Piusi OCIO gauge for tank reading and low level alert.

**SWS2010**—3 compartment mains alarm with probes for tank

All assembled fuel conditioners and parts are RTB warranty and any replacements do not extend the overall warranty period. Refer to our T&C's for further information.

# TROUBLESHOOTING & FAQ

## FILTER BLOCKED Alarm comes on whilst the pump is still programmed to run

- Could be taking too long to prime once the pump starts – try changing the flow delay settings.
- Ensure the fuel pickup is far enough away from the fuel delivery (suction should be close to the pump and delivery should be to far side of the tank) as there is now air entering the system Try to shorten the time that the pump runs for.
- Check the filters... they are probably blocked.
- Check that the minimum pipe dimension of 1" I/D pipe is being used.
- Check the supply voltage is within tolerance—if not reduce the pump run time.
- Check the pump switch is in the ON position.
- Check for the RED Led inside the control box to activate the pump relay.
- Is there enough fuel in the tank ?

## FILTER BLOCKED Alarm comes on after the system has only run a few cycles

- Likely that the filters are actually blocked! Check the alarm log to verify if the degraded filters were registered.
- If the fuel has never been filtered before the recirc unit is fitted then the filters will block quickly and are doing their job. Change filters and run unit again.
- Ideally the fuel should be polished before the recirc unit is used... or fresh fuel should be in the tank when the recirc unit is fitted.
- Check to see that the min pipe dimension of 1" I/D pipe is being used.

## FUSES

All fuses are 20mm glass fuses

F1 (PUMP) is 5A Slow-blow

F2 and F3 (INPUTS) are 100mA Normal

F4 (PSU) is a 2A Normal

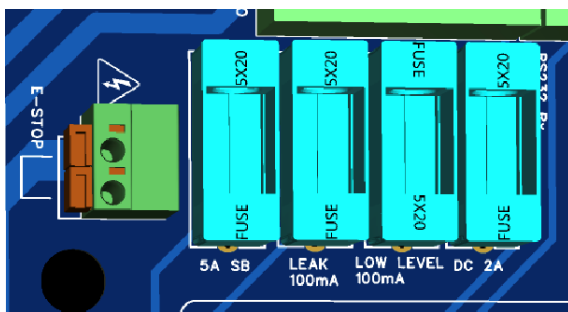

*Fuses are revealed by opening the main cover. Isolate all power before proceeding. Spare fuses are found on the rear removable panel.*

## Time and / or Date is shown incorrectly on the screen

Enter “Engineer” menu

Click on the Time/Date at the top right of the screen

Adjust as required

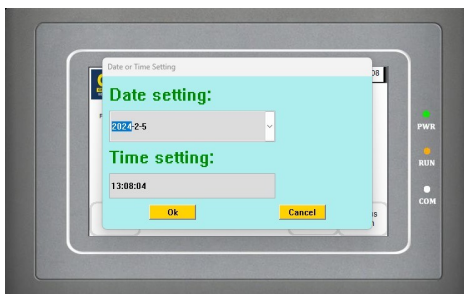

Note: Cycle power after changing date/time



## How to run the system manually to re-prime or check for any leaks

Enter the “Engineer” menu

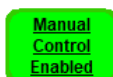
Click “Manual Control” button (which turns green)



Return to main screen

Now PRESS and hold  to run the pump and then press  once finished

Remember to log out of the “Engineer “menu.

*The MANUAL mode will time out automatically*

### Centre Tank Services Ltd

Model: Fuel Conditioner with MODBUS and/or Level Gauge - CTS1081, CTS1082, CTS1083.

Input: 230v AC 50Hz—4.5A



MADE IN UK

